

Read this Instructions For Use carefully before testing.

For in vitro diagnostic use only

MIZUHO MEDY Co., Ltd.

Clostridium difficile kit Quick Chaser CD GDH/TOX

[General precautions]

- 1) Do not use this product for purpose other than in vitro diagnosis.
- 2) The diagnosis of *Clostridioides*(*Clostridium*)*difficile* infection should be comprehensively made not only by the test result of this product, but also in conjunction with the assessment of clinical progress and results of other tests.
- 3) Procedures other than described in this instruction for use are not guaranteed.

[Package]

68500: Quick Chaser CD GDH/TOX - 10 tests/kit

[Contents]

- 1) Test plate - 10 tests
 - Mouse monoclonal anti-*Clostridioides difficile* antigen (glutamate dehydrogenase) antibodies (Mouse monoclonal anti-GDH antibodies)
 - Mouse monoclonal anti-*Clostridioides difficile* toxin A antibodies (Mouse monoclonal anti-toxin A antibodies)
 - Mouse monoclonal anti-*Clostridioides difficile* toxin B antibodies (Mouse monoclonal anti-toxin B antibodies)
 - Colloidal gold conjugated to mouse monoclonal anti-*Clostridioides difficile* antigen (glutamate dehydrogenase) antibodies (Colloidal gold conjugated to mouse monoclonal anti-GDH antibodies)
 - Colloidal gold conjugated to mouse monoclonal anti-*Clostridioides difficile* toxin A antibodies (Colloidal gold conjugated to mouse monoclonal anti-toxin A antibodies)
 - Colloidal gold conjugated to mouse monoclonal anti-*Clostridioides difficile* toxin B antibodies (Colloidal gold conjugated to mouse monoclonal anti-toxin B antibodies)
- 2) Extraction reagent solution vial-1mL×10 vials
Extraction reagent solution is buffer containing detergent
- 3) Swab (non-sterile)-10 pieces
- 4) Rack (for extraction reagent solution vial)- 1 piece
- 5) Filter (for extraction reagent solution vial)-10 pieces
- 6) Blue cap (for temporary storage of extraction reagent solution vial)- 10 pieces
- 7) Name label for extraction reagent solution vial- 1 sheet

[Intended use]

For detection of *Clostridioides* (*Clostridium*) *difficile* antigen and toxins (toxin A and toxin B) in feces
(An aid of diagnosis for *Clostridioides* (*Clostridium*) *difficile* infection)

[Principle of the test]

Quick Chaser CD GDH/TOX is the in vitro reagent for detection of *Clostridioides difficile* antigen and toxins (toxin A and toxin B) based on Immunochromatographic Assay.

Colloidal gold conjugated to mouse monoclonal anti-GDH antibodies, colloidal gold conjugated to mouse monoclonal anti-toxin A antibodies, colloidal gold conjugated to mouse monoclonal anti-toxin B antibodies and colloidal gold conjugated to rabbit immunoglobulin for control lines are coated in each sensitized colloidal gold coating area on a membrane filter which is set in test plate. Mouse monoclonal anti-GDH antibodies are immobilized in test line area on GDH side, mouse monoclonal anti-toxin A antibodies and mouse monoclonal anti-toxin B antibodies are immobilized in test line area on TOX side, and anti-rabbit immunoglobulin antibodies for control lines are immobilized in each control line area.

If GDH or toxins are present in the sample, according to the principle of immunochromatography, GDH react with colloidal gold conjugated to mouse monoclonal anti-GDH antibodies, toxins each react with colloidal gold conjugated to mouse monoclonal anti-toxin A antibodies and colloidal gold conjugated to mouse monoclonal anti-toxin B antibodies, as they migrate from the sample area. Moreover, they will be captured in GDH test line area and toxin test line area by reacting with mouse monoclonal anti-GDH antibodies or mouse monoclonal anti-toxin A antibodies, mouse monoclonal anti-toxin B antibodies. As a result, purple-red lines with the colloidal gold, appear in each test line area.

At the same time, the colloidal gold conjugated to rabbit immunoglobulins also migrate and will be captured by the anti-rabbit immunoglobulin antibodies on each control line areas, resulting in the appearance of a purple-red lines in control line areas regardless of the presence or absence of GDH and toxins.

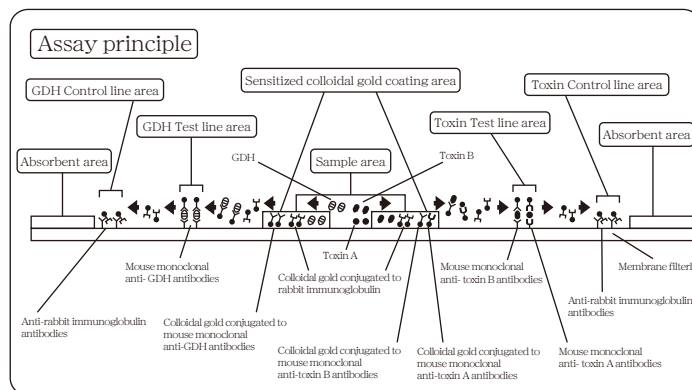

[Procedural precautions]

- 1) Use fresh natural fecal specimen for testing.
- 2) Be sure to use the swab included in the kit when collecting samples.
- 3) Use the collected specimen as soon as possible in accordance with instruction of sample preparation in "Test procedure". Specimen can be stored refrigerated for up to 72 hours. If the sample cannot be prepared right away or specimen needs to be preserved for a long period of time, store the specimen under -30°C and avoid repeating the freezing and thawing.
- 4) Avoid storage of suspended extraction reagent solution.
- 5) Do not use specimen stored in formalin or polyvinyl alcohol.
- 6) Do not use specimen of asymptomatic carrier, or of patient after anti *C. difficile* antibiotic administration.
- 7) When testing, make homogeneous mixtures of fecal specimen and extraction reagent solution by mixing thoroughly.
- 8) Collect adequate volume of specimen. Insufficient volume may cause false-negative results and excessive volume may cause indeterminate results due to filter clogging or poor sample flow.
- 9) When dropping the sample, drop predetermined volume (4 drops) into the center of sample area while allowing droplets to form by keeping the tip of filter about 10mm away. Dropping sample volume other than predetermined volume may cause inaccurate reaction.
- 10) Bring test plate and extraction reagent solution to 15 - 30 °C prior to testing.
- 11) Be sure to read results within the predetermined reaction time as failing to do so may cause false-negative or false-positive.
- 12) Interfering substances and medications

The following substances and blood did not interfere with the performance of this product at the concentration listed below:

Mucins	0.36%
Intralipos®	0.36%
Blood	3.6%
Hemoglobin	45.5mg/dL
Barium sulfate	0.46%
Stearic acid/Palmitic acid	4.5%
Metronidazole	0.14%
Vancomycin	0.18%
Fidaxomycin	0.036%

13) Cross reactivity

Cross reactivity with the following bacteria and viruses were not observed.

• Bacteria

Aeromonas hydrophila, *Bacillus cereus*, *Bacillus subtilis*, *Bacteroides fragilis*, *Campylobacter coli*, *Campylobacter jejuni*, *Citrobacter freundii*, *Candida albicans*, *Clostridium beijerinckii*, *Paraclostridium bifermentans*, *Clostridium butyricum*, *Clostridium clostridioforme*, *Clostridium histolyticum*, *Clostridium innocuum*, *Clostridium novyi*, *Clostridium perfringens*, *Clostridium septicum*, *Paeniclostridium sordellii* (nontoxigenic), *Clostridium sporogenes*, *Clostridium tertium*, *Klebsiella aerogenes*, *Enterobacter cloacae*, *Enterococcus faecalis*, *Escherichia coli*, *Escherichia coli* EIEC, *Escherichia coli* ETEC, *Escherichia coli* O157:H7, *Klebsiella oxytoca*, *Klebsiella pneumoniae*, *Peptostreptococcus anaerobius*, *Porphyromonas asaccharolytica*, *Proteus mirabilis*, *Proteus vulgaris*, *Pseudomonas aeruginosa*, *Salmonella* Typhimurium, *Serratia liquefaciens*, *Shigella dysenteriae*, *Shigella flexneri*, *Shigella sonnei*, *Staphylococcus aureus*, *Staphylococcus epidermidis*, *Vibrio cholerae*, *Vibrio parahaemolyticus*, *Yersinia enterocolitica*

• Virus

Rotavirus A, Adenovirus type 40, Adenovirus type 41

[Test procedure]

● Specimen collection

1) Preparation of specimen collection

- ① Extraction reagent solution : No prior preparation required.
- ② Swab: Use swab (non-sterile) included in this kit

2) Specimen collection

Collect specimen using the swab included in this kit.

- In case of watery diarrhea, soak the whole swab tip with specimen.
- In case of loose or solid feces, collect specimen by scraping evenly so that the feces cover the half of swab tip.

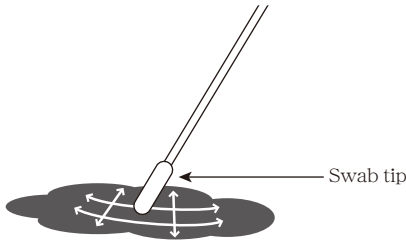

3) Adequate specimen volume

Watery diarrhea (75~150μL)			Solid feces (50~100mg)			
Insufficient	Adequate	Adequate	Insufficient	Adequate	Adequate	Excessive

● Details of extraction reagent solution vial

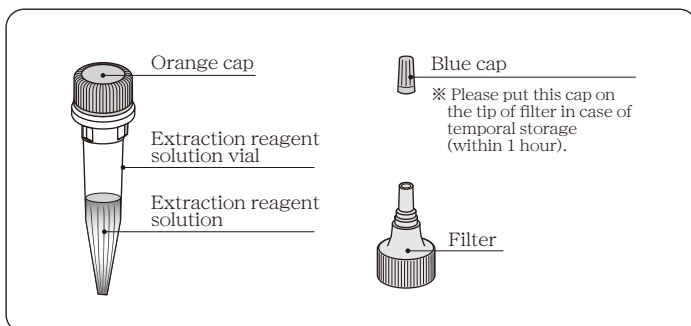

● Sample preparation

① Remove orange cap.

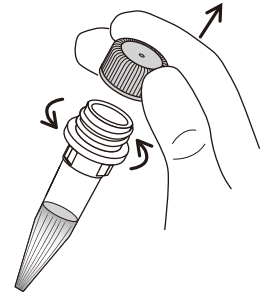

② Insert the swab tip with specimen into the bottom of extraction reagent solution vial.

Squeeze the swab tip lightly from the outside of the vial, rotate the swab for about 5 times, and rub the swab tip onto the side and bottom of the vial. Squeeze solution out of swab tip as removing swab.

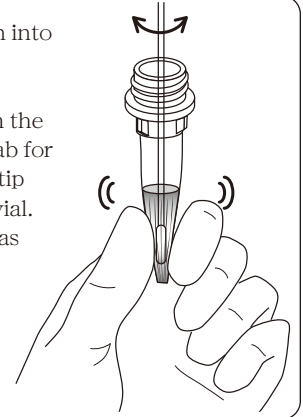

Attention) Do not leave the fecal suspension for more than 1 hour after suspension.

③ Install the filter and shake the vial gently to mix specimen thoroughly. The sample is ready for use.

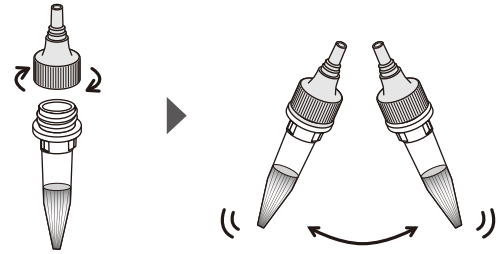

● Details of test plate

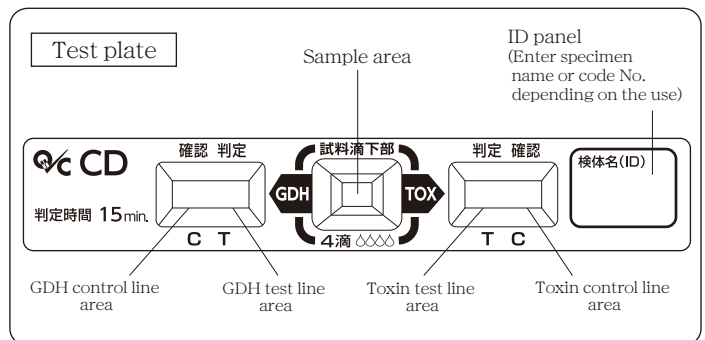

● Test procedure

1) Sample preparation

Test plate: No prior preparation required

2) Test procedure

① Remove test plate from aluminum foil pouch.

Discard desiccant sheet included in aluminum foil pouch.

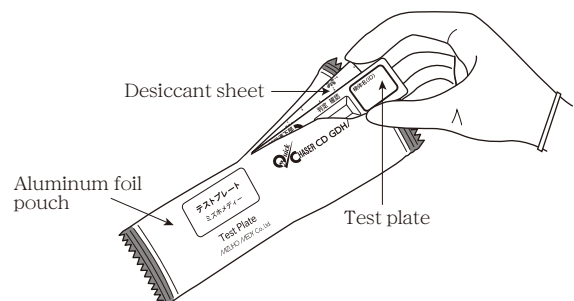

- ② Add 4 drops (approx. 150 μ L) of prepared sample vertically to the sample area of test plate from the extraction reagent solution vial, while avoiding the tip to contract with sample area.

※Drop predetermined volume while keeping the tip of filter away from the sample area about 10mm.

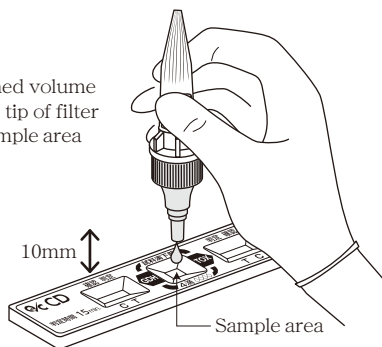

- ③ Leave to react at 15-30°C.

Visually interpret test result by lines in the test line area and control line area after 15 minutes.

However, if lines appear in control line areas and test line areas (both GDH and TOX) before 15 minutes, positive results can be interpreted.

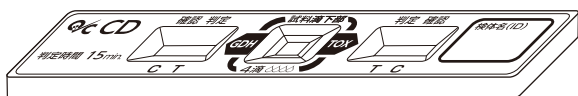

[Interpretation]

Interpret by presence of red-purple lines in each test line area and control line area.

《GDH Positive/TOX Negative》

GDH test line, GDH control line and TOX control line appear.

GDH Positive/
TOX Negative



《GDH Positive/TOX Positive》

GDH test line, GDH control line, TOX test line and TOX control line appear. In this case, results can be interpreted before 15 minutes.

GDH Positive/
TOX Positive



《GDH Negative /TOX Negative》

Control lines appear in each control line area.

GDH Negative/
TOX Negative



《Retest》

If no line appears in either of control line area, operational mistakes such as the insufficient sample volume are considered. Recheck test procedure and retest with new test plate. If the same result comes out in the retest again, confirm with other method.

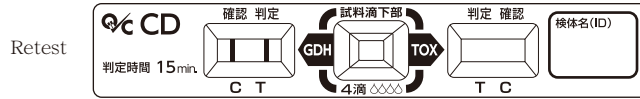
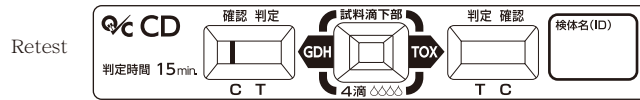
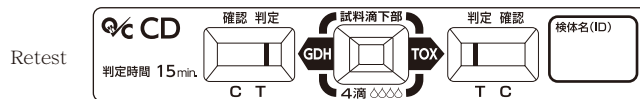
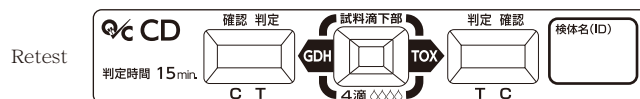

《Indeterminate》

If TOX test line and TOX control line and GDH control line appear while GDH test line does not, results are indeterminate. Retest using a new specimen, or use other testing method.

Indeterminate



● Interpretational precautions

- In cases where GDH test line, GDH control line, TOX test line and TOX control line appear before 15 minutes after adding sample, it can be interpreted as GDH Positive/TOX Positive. Results of any other case should be interpreted at 15 minutes after adding sample. Streak line may appear temporarily due to flow of colloidal gold. Please note that this is not a test line. After interpretation time, colloidal gold can appear line-like due to drying of test plate with time. Therefore, interpret test results at the predetermined time.
- This product is used as an aid in the diagnosis for infection of *Clostridioides difficile*. In such cases where *Clostridioides difficile* GDH and toxins in specimen are below the detection limit of the test or specimen collection is not sufficient, test result could be interpreted as negative, even though patients are infected by *Clostridioides difficile*. Moreover, special factors in specimen could cause non-specific reaction and negative specimen could be interpreted as positive. The definitive diagnosis should be made comprehensively in conjunction with the assessment of clinical progress and another test result.
- Toxin HT (hemorrhagic toxin) and Toxin LT (lethal toxin) of *Paenicostridium sordellii* show homology with toxins of *Clostridioides difficile*, therefore they may show cross-reactivity with this product.

[Performance characteristics]

- 1) Performance

① Sensitivity

- When GDH positive control ^{note1)} was tested, a GDH positive result was shown.
- When toxin A positive control ^{note2)} and toxin B positive control ^{note3)} were tested, TOX positive results were shown.

② Accuracy

- When GDH positive control was tested, a GDH positive result was shown.
- When toxin A positive control and toxin B positive control were tested, TOX positive results were shown.
- When negative control ^{note4)} was tested, a negative result was shown for both GDH and TOX.

③ Reproducibility

- When GDH positive controls were tested three time simultaneously, GDH positive results were shown in all cases.
- When toxin A positive control and toxin B positive control were tested three time simultaneously, TOX positive results were shown in all cases.

- When negative controls were tested three time simultaneously, negative results were shown in all cases.
Note 1) GDH antigen control solution is diluted by extraction reagent solution to be equivalent to 1.20ng/mL of calibration reference material
Note 2) Toxin A antigen control solution is diluted by extraction reagent solution to be equivalent to 2.68ng/mL of calibration reference material
Note 3) Toxin B antigen control solution is diluted by extraction reagent solution to be equivalent to 2.00ng/mL of calibration reference material
Note 4) Extraction reagent solution

④ Detection limit

Detection of GDH: GDH 0.30ng/mL

Detection of Toxins: Toxin A 0.67ng/mL

<GDH>

Comparison with existing approval product (enzyme immunoassay)

		Quick Chaser CD GDH/TOX		
		Positive	Negative	Total
Other product (1)	Positive	100	0	100
	Negative	2 ※1	139	141
	Total	102	139	241

Positive agreement rate : 100%(100/100)
Negative agreement rate : 98.6%(139/141)
Total agreement rate : 99.2%(239/241)

※1 Regarding two cases where results were negative with Other product (1) but positive with QC CD GDH/TOX, they were both positive with Other product (2).

Comparison with existing approval product (immunochromatographic assay)

		Quick Chaser CD GDH/TOX		
		Positive	Negative	Total
Other product (2)	Positive	102	14 ※2	116
	Negative	0	125	125
	Total	102	139	241

Positive agreement rate : 87.9%(102/116)
Negative agreement rate : 100%(125/125)
Total agreement rate : 94.2%(227/241)

※2 Regarding fourteen cases where results were positive with Other product (2) but negative with QC CD GDH/TOX, they were all negative with Other product (1).

<Toxins>

Comparison with existing approval product (enzyme immunoassay)

		Quick Chaser CD GDH/TOX		
		Positive	Negative	Total
Other product (1)	Positive	54	2 ※4	56
	Negative	2 ※3	183	185
	Total	56	185	241

Positive agreement rate : 96.4%(54/56)
Negative agreement rate : 98.9%(183/185)
Total agreement rate : 98.3%(237/241)

※3 Regarding two cases where results were negative with Other product (1) but positive with QC CD GDH/TOX, one case was positive with Other product (2) and the other was negative with Other product (2).

※4 Regarding two cases where results were positive with Other product (1) but negative with QC CD GDH/TOX, one case was positive with Other product (2) and the other was negative with Other product (2).

Comparison with existing approval product (immunochromatographic assay)

		Quick Chaser CD GDH/TOX		
		Positive	Negative	Total
Other product (2)	Positive	55	4 ※6	59
	Negative	1 ※5	181	182
	Total	56	185	241

Positive agreement rate : 93.2%(55/59)
Negative agreement rate : 99.5%(181/182)
Total agreement rate : 97.9%(236/241)

※5 Regarding one case where result was negative with Other product (2) but positive with QC CD GDH/TOX, it was negative with Other product (1).

※6 Regarding four cases where results were positive with Other product (2) but negative with QC CD GDH/TOX, one case was positive with Other product (1) and three cases were negative with Other product (1).

Toxin B 0.50ng/mL

2) Correlation

3) Calibration reference material (Standard material)

- Recombinant GDH protein
- Toxin A purified from *Clostridioides difficile*
- Toxin B purified from *Clostridioides difficile*

[Precautions for use and handling]

1) Precautions for handling (Prevention of danger)

- Infectious materials other than *Clostridioides difficile* could be included in sample (specimen). Handle sample (specimen) as potentially infectious materials.
- When using, avoid sample (specimen) and/or extraction reagent solution from directly contacting skin and eyes by wearing protection devices (safety glasses, gloves, surgical masks etc.).
- Do not collect specimen with swab which had been immersed in extraction reagent solution.
- If sample (specimen) and/or extraction reagent solution gets into eyes or mouth, flush with a plenty of water as a first aid

treatment and seek medical attention if necessary.

- Blue cap included in the kit is not airtight. Do not use it for purposes of transportation and storage.
- Material of membrane used for test plate is nitrocellulose. Do not use this product near the fire as nitrocellulose is extremely flammable.
- In case where the sample (specimen) is spattered, wipe off with sodium hypochlorite solution (effective chlorine concentration of 5,000ppm).
- Be careful when handling the specimens and utensils that had come into contact with specimens, as they may cause secondary infection.

2) Precautions for use

- Do not freeze this product. Store this product in accordance with description of instruction for use. Do not use frozen reagents as they could show false result due to change of quality.
- Do not use this product beyond expiration date.
- Do not store the extraction reagent solution on sideways or upside down.
- Use only dedicated extraction reagent solution included in the kit, and do not use extraction reagent solution from other kits.
- Use the test plate immediately after opening aluminum foil pouch. If test plate is left in a room for a long period of time, it may not react due to exposure to moisture.
- Do not touch sample area, test line area and control line area directly by hands.
- Avoid performing test in the place where the dry wind directly blows the surface of the test plate such as under air conditioner, to prevent uneven sample migration.
- Do not use this product for purposes other than described in "intended use" of this instruction for use.
- Test plate, swab and extraction reagent solution (including caps) are for single-use only.
- Use swab included in the kit.
- Do not touch swab tip with hand before use.
- If swab is stained, broken or bent, do not use it.
- Do not collect specimen from rectum.
- Be careful not to splatter the sample at the time of taking the swab out of vial after preparing sample.
- In case collected volume of specimen is excessive, or specimen is high viscous, membrane filter may clog and adequate sample volume could not be dropped. In such cases, collect specimen again and retest with new test plate. If membrane filter clogs again, dilute the specimen 2-3 times with saline or extraction reagent solution, and perform the test. When using diluted specimen, perform a test starting with the specimen collection step by following the test procedure.

3) Precautions for waste disposal

- Handle liquid waste and used utensils by any of following sterilization methods as sample (specimen) may contain infectious material other than *Clostridioides difficile*.
 - Immerse in sodium hypochlorite solution (effective chlorine concentration of 1,000 ppm) for 1 hour or more
 - Immerse in 2 % glutaraldehyde solution for 1 hour or more
 - Autoclave at 121 degree Celsius for 20 minutes or more
- Regarding disposal of used reagent and utensils, dispose of them in accordance with Local Regulation and Law of waste disposal.

[Storage • Expiry]

- Storage: 1-30°C
- Expiry: 6 months (as indicated on package)

Technical information
Telephone +81-942-85-3845

Manufacturer: **Mizuho Medy Co.,Ltd.**

5-4 Fujinoki-machi, Tosu City, Saga, 841-0048 Japan

<https://www.mizuho-m.co.jp/en>